

Reference Cell

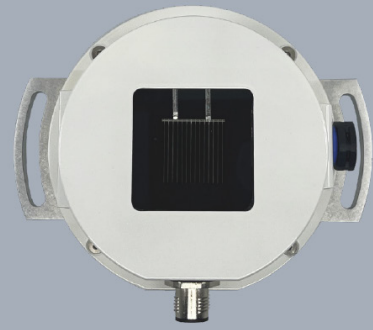

PV-MON



Soiling loss monitoring at maximum power point

Words: Kees Hoogendijk, Technical Director at EKO Instruments Europe B.V.

In the quest for optimizing photovoltaic (PV) system performance, accurate soiling loss monitoring is crucial. Soiling, the accumulation of dirt, dust, and debris on PV panels, significantly impacts energy production. Traditional methods measure soiling loss at the short circuit current (I_{sc}) or with soiling ratio (SR) detectors, but this approach often fails to provide a true representation of power loss at PV array level. Monitoring at the Maximum Power Point (MPP) instead offers a precise assessment, reflecting the actual operational conditions of the PV system.

The market is flooded with diverse soiling loss measurement solutions, each varying in accuracy and reliability. After years of exploration and innovation, it has become clear that MPP soiling loss monitoring is the way forward.

This method delivers superior data accuracy, enabling timely and effective maintenance decisions. Embracing MPP monitoring ensures PV systems operate at peak efficiency, driving the future of renewable energy towards greater reliability and performance.

Pioneering precision

EKO Instruments has long been a leader in the field of solar irradiance measurement and the evaluation of photovoltaic (PV) module performance. With decades of expertise, we understand the intricacies of PV system performance and the various factors that can impact it. One of the most significant contributors to performance loss in PV systems, is soiling, the accumulation of dirt, dust, and debris on the panels.

Soiling loss at the PV string level is influenced by a myriad of factors, including environmental conditions, optical characteristics, and properties of the PV modules. Effective monitoring of soiling ratio (SR), therefore, requires a comprehensive approach that accounts for all these aspects. We recognize this complexity and have developed an easy to use solution that provides clear, actionable information about true performance loss.

Many existing solutions on the market provide only some indication of soiling but fail to measure actual power performance loss at the string level. This gap in accurate, actionable data is often due to the challenge of non uniform soiling, where the distribution of contaminants across the PV array is uneven, making it difficult to draw meaningful conclusions from the data.

EKO Instruments has addressed this issue by focusing on total power monitoring at the string level of the actual PV array deployed. This approach ensures that the impact of soiling loss is fully understood in the context of overall system performance. By monitoring power at the Maximum Power Point (MPP) rather than just the short circuit current (Isc) of a witness module, EKO's solution captures the true effect of soiling on energy production. This comprehensive monitoring is essential for optimizing maintenance and ensuring that PV systems operate at peak efficiency.

The new solution aligns with the requirements of IEC 61724-1, which mandates rigorous monitoring of both the available irradiance and the soiling performance loss of a PV system. This standard emphasizes the importance of accurate soiling loss measurement as part of a broader framework for PV system performance assessment, ensuring that all aspects of environmental and operational conditions are accounted for in the evaluation process.

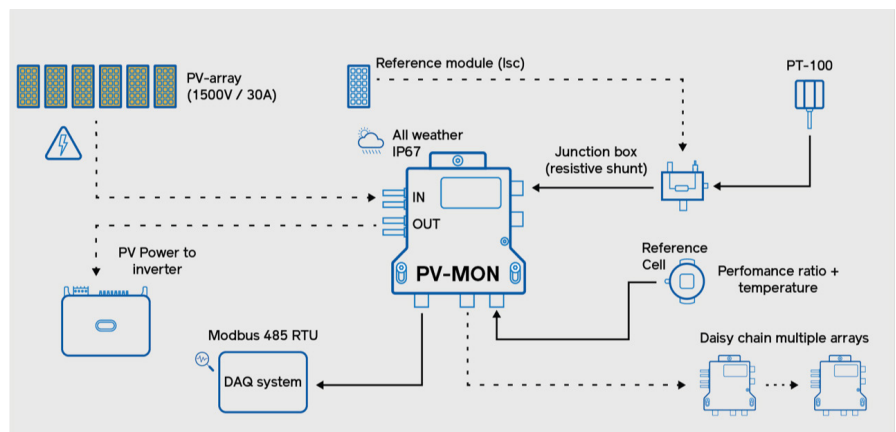

PV-MON soiling loss monitoring at maximum power point

In summary, EKO Instruments' holistic approach to soiling loss monitoring at the MPP level represents the future of PV system optimization, providing clear, reliable data that drives better performance and greater efficiency in solar energy systems.

Innovative monitoring with PV-MON

At the forefront of photovoltaic (PV) system performance optimization, we have developed an advanced method for monitoring the soiling loss ratio at the Maximum Power Point (MPP). The core of this solution is PV-MON, a high quality and calibrated power measurement device engineered to accurately measure the instantaneous power output of PV strings. This cutting edge technology realizes precise assessment and effective maintenance of PV systems, maximizing their efficiency and energy yield.

Key features of PV-MON

Accurate power measurement

PV-MON excels in measuring the instant power of high capacity PV strings (1500 V/30A) independently from the inverter, but based on the inverter MPP tracking point. This operating point is set by the inverter based on the soiling affected actual current and voltage output of the PV string. PV-MON works in a transparent mode and doesn't interrupt the PV power production. It just measures the true output and enables PV operators to make informed decisions about maintenance and cleaning schedules, thereby optimizing the overall system performance.

PV-MON accurately measures the instant power of high capacity PV strings (1500V/30A) without relying on the inverter but uses the inverter's MPP tracking point, which adjusts for soiling effects on the current and voltage output. It operates transparently without interrupting power production, helping operators make informed maintenance and cleaning decisions to optimize system performance.

Clean reference for benchmarking

A distinctive feature of PV-MON is its use of either a clean reference module or a clean

reference cell to establish the maximum power of the string in a clean state at MPP level. The use of a clean reference module is particularly beneficial due to its identical properties to the modules applied to the PV string, effectively eliminating any mismatch caused by differing optical properties. This ensures that the power loss ratio due to soiling is measured accurately and reflects the actual conditions of the entire PV array.

For the reference module or cell to provide accurate benchmarking, it is crucial to maintain its cleanliness. Regular cleaning of the reference is essential to represent the unaffected maximum power point and calculate the SR MPP of the PV string accurately. Neglecting this aspect can lead to skewed data and ineffective maintenance strategies, undermining the system's performance optimization efforts.

Temperature adjustment for enhanced accuracy

Temperature variations can significantly impact the power output of PV modules. So, PV-MON incorporates a high precision Class A Pt-100 temperature sensor for back module temperature measurements to adjust for temperature dependency effects. By integrating temperature data and module temperature characteristics Alpha, Beta, Kappa, PV-MON let you calculate more accurately MPP performance loss due to soiling. This comprehensive approach ensures that all relevant environmental factors are considered, providing a true picture of the soiling impact on the PV system.

Integrated into your PV system

One of the standout features of PV-MON is its ease of integration and installation. The all weather system components are designed to be seamlessly incorporated into both new and existing PV monitoring solutions through the universal Modbus 485 RTU interface. This flexibility aspect makes PV-MON a valuable tool for PV system operators seeking to upgrade their monitoring capabilities without extensive overhauls.

Our goal at EKO is to become your one stop measurement solution provider for reliable PV performance research and monitoring.

PV-MON processes all basic data onboard, ensuring rapid and reliable analysis. A configuration tool allows for easy setup and integration. The processed data is accessible through a Modbus output, which can be connected to any Data Acquisition (DAQ) or SCADA controlled monitoring solution. This compatibility with standard data interfaces simplifies the integration process and enhances the usability of the system.

Furthermore, PV-MON is a modular system, allowing for easy expansion to monitor multiple strings through a single Modbus cable. It features multiple inputs for EKO pyranometers and reference cells, enabling the construction of a comprehensive irradiance and MPP level soiling monitoring system.

Underestimated impact of non uniform soiling

Non uniform soiling significantly impacts the accuracy of soiling loss ratio calculations in PV systems, particularly when output power at starting level is not measured and non uniform soiling is ignored. Current market solutions often fail to account for the soiling gradient across large surfaces, leading to unreliable data causing differences of multiple percent.

Soiling is rarely uniform; it typically varies across the PV array, creating a gradient that influences the electrical output differently depending on the cell layout and electrical design. The presence of a gradient and semi transparent soiling film on the PV surface filters light rays variably, affected by factors such as the angle of incidence and the spectral energy distribution throughout the day.

Soiling loss is dynamic and fluctuates with these optical parameters, showing a pattern that changes throughout the day and potentially accumulates over time. Therefore, it is not a constant value but a variable one, influenced by daily and seasonal variations, and only significantly altered by external factors like rain or manual cleaning.

In the context of non uniform soiling on PV panels, measuring short circuit current (I_{sc}) and current at maximum power point (I_{mpp}) yields different insights. I_{sc} reflects the maximum current under virtual short circuit load conditions and is less sensitive to variations in soiling across the panel. Conversely, I_{mpp} measures the current when the PV array is delivering maximum power, capturing the true impact of non uniform soiling on energy production. Thus, I_{mpp} provides a more accurate and realistic assessment of performance loss due to soiling compared to I_{sc} at PV module level which overestimates the output.

Many current solutions overlook these complexities, leading to oversimplified and inaccurate soiling loss assessments. Our approach recognizes that while the science behind measuring all optical parameters can become overly complex and impractical, a more straightforward yet comprehensive method is essential.

By focusing on a more extensive surface area for soiling measurement and correlating it directly with output power, we provide a more accurate representation of soiling loss at the PV plant. This ensures better reliability and efficiency in monitoring and managing soiling effects, making our solution simpler and more effective compared to others in the market.

Conclusion

EKO Instruments' PV-MON based solution represents a significant advancement in soiling loss monitoring technology. By focusing on MPP measurements and utilizing clean reference modules or cells, PV-MON provides accurate, reliable data that directly correlates to power performance loss at the PV string level. Its comprehensive approach, including temperature adjustments and easy integration, ensures that PV systems can maintain optimal performance, maximizing energy production and efficiency.

With its modular design and compatibility with standard data interfaces, PV-MON is poised to revolutionize the way PV systems are monitored and maintained, solidifying our position as an innovation leader in the solar energy measurement industry.

We are thrilled to announce our new solution, which will begin its gradual entry into the global market starting in Q4 2024. Shortly, we will be adding more functions to our products, aiming to achieve a truly maintenance free solution. By leveraging our optical expertise, we will integrate advanced irradiance measurement capabilities to precisely determine power availability, correlating it directly with the output power of your PV systems.

Our goal at EKO is to become your one stop measurement solution provider for reliable PV performance research and monitoring. This enhancement will simplify the process, reduce the need for frequent maintenance, and ensure more accurate and reliable data for our clients, reinforcing our commitment to innovation and customer satisfaction.

🌐 www.eko-instruments.com

References:

IEC 61724-1: Photovoltaic system performance – Part 1: Monitoring

Soiling effect in solar energy conversion systems (<https://doi.org/10.1016/j.rser.2022.112434>)

Investigation on temperature dependence of recent high-efficiency silicon solar modules (<https://doi.org/10.1016/j.solmat.2023.112649>)

Accurate Soiling Ratio Determination With Incident Angle Modifier for PV Modules

(<https://doi.org/10.1109/JPHOTOV.2018.2882468>)

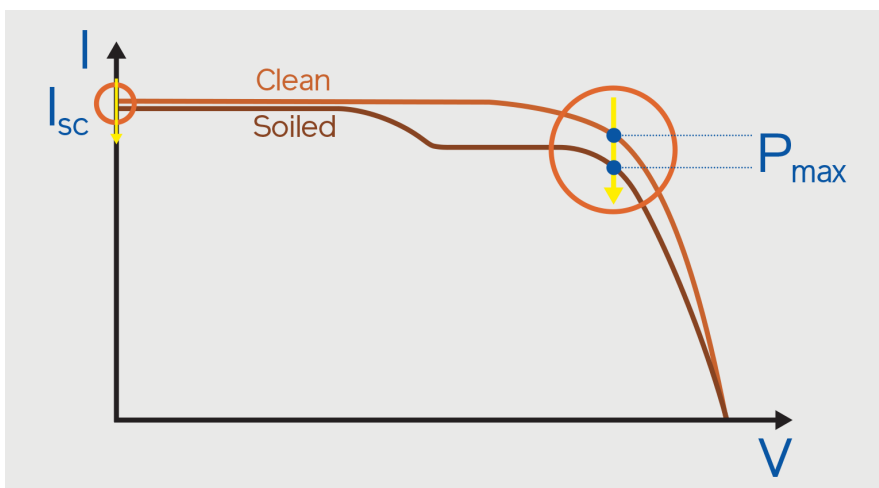

I_{sc} versus I_{mpp}