

Figure 1. Hydraulic pitch system. Source: HINE

Failure modes in offshore wind turbines: pitch systems

The reliability of an offshore wind turbine and the resources required to maintain it can make up ~30% of the overall cost of energy, thus determining and understanding offshore wind turbine failure rates is vital for modelling and reducing O&M costs and in turn minimizing the levelized cost of energy (LCoE).

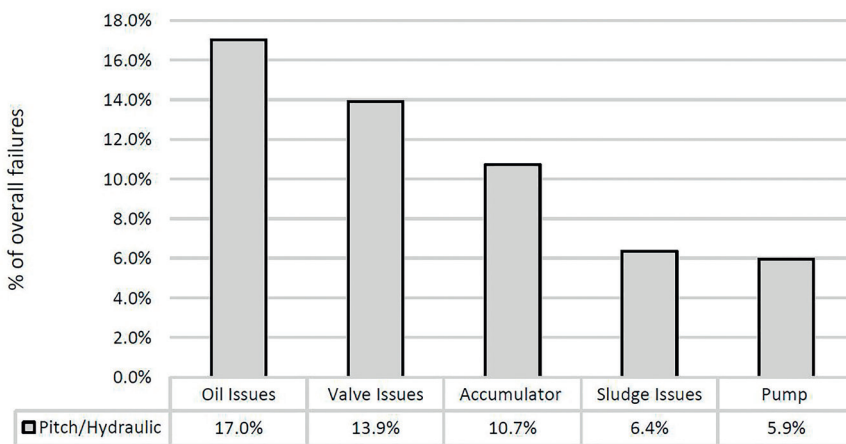
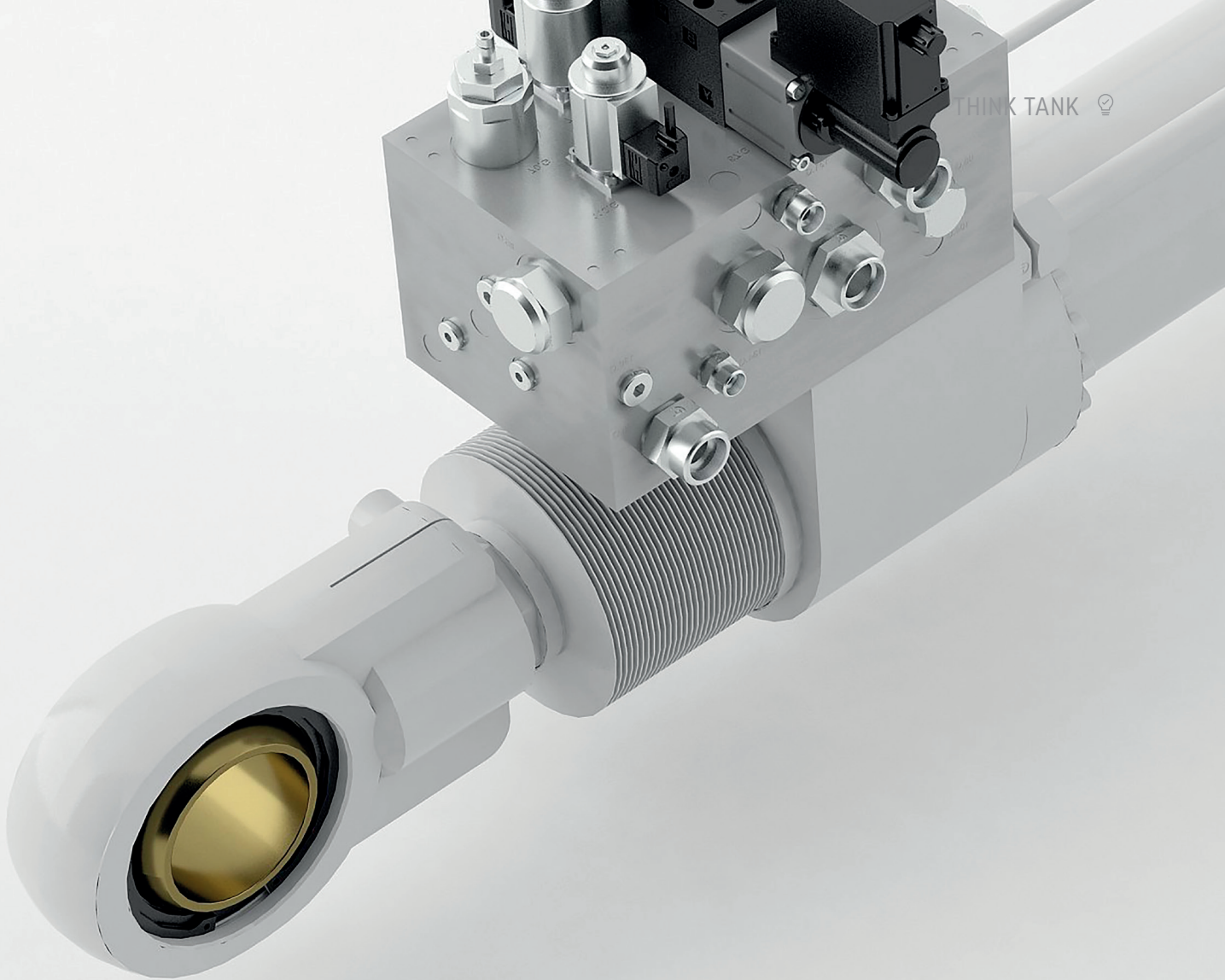

Figure 2 Pitch/hydraulic failure modes. Source: "Failure rate, repair time and unscheduled O&M cost analysis of offshore wind turbines"

One of the main optimization challenges that offshore wind faces is the cost of Operation and Maintenance activities, especially because of the difficulties associated with access for maintenance. The reliability of an offshore wind turbine and the resources required to maintain it can make up ~30% of the overall cost of energy, thus determining and understanding offshore wind turbine failure rates is vital for modelling and reducing O&M costs and in turn minimizing

the levelized cost of energy (LCoE).

Even if the documentation on offshore failure rates is rather poor in the past, some recent analyses have already identified the most critical components for the failure rate of wind turbines.

'Failure rate, repair time and unscheduled O&M cost analysis of offshore wind turbines', an analysis of ~350 modern multi MW scale offshore wind turbines over a five year period

reported in 2015 by Carroll et al.¹, shows that as a subsystem, the hydraulic pitch system can be kept in working order by means of regular maintenance, with most repairs consisting of a change or top-up of oil, the cleaning of sludge accumulated on a sensor, the fixing of a leak or the replacement of a valve, accumulator or pump, as shown by Figure 2. However, the hydraulic system is responsible for blade pitch angle control and drivetrain and yaw system braking.

Therefore, a hydraulic system failure, although likely simple and cheap to repair, can critically impact turbine availability and loads if it remains undetected.

A paper published by Jesper Liniger et al.² takes a root-cause-based approach, applies it specifically to hydraulic pitch systems and provides a design tool for risk evaluation in the early design phase to facilitate qualitative analysis of reliability.

The tool calculates a Risk Priority Number

1 'Failure rate, repair time and unscheduled O&M cost analysis of offshore wind turbines.' Article in Wind Energy · August 2015. Authors: James Carroll, David Mcmillan & Alasdair Mcdonald

2 'Reliability Based Design of Fluid Power Pitch Systems for Wind Turbines'. Research article. Authors: Jesper Liniger, Mohsen Soltani, Henrik C. Pedersen, James Carroll, Nariman Sepehri

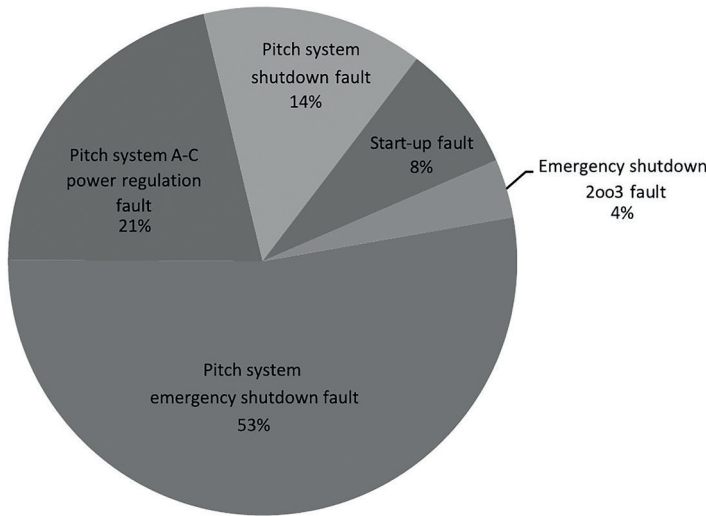

Figure 3 Pitch system RPN distribution. Source: 'Reliability based design of fluid power pitch systems for wind turbines'

(RPN), which is a measure of criticality for each failure mode of a system. The result of the RPN is the product of three factors: probability, severity, and probability of no detection; thus, a higher RPN indicates a weaker spot in the system in terms of risk. In this case, the RPN has been considered a measure of combining both turbine integrity and loss of production.

According to the ensuing analysis, an emergency shutdown fault in a single pitch system seems to be the largest contributor to the system RPN. This is understandable, because turbine integrity can be compromised by operation with a faulty emergency shutdown circuit, since shutdown would not take place as designed in case of an emergency, and the authors do not consider such a fault detectable, since the shutdown circuit does not do much during normal operation. An overview of the total system RPN distribution is seen in Figure 3.

The relevance of the hydraulic pitch system in the reliability of the wind turbines, pushed DOCC-OFF project partners to design a data monitoring and analysis system to increase the probability of detection of the critical failure modes. Reducing the probability of not detecting the failure in time will also reduce the RPN, whereby the component will be less critical.

DOCC-OFF is an EU-funded project, in which 4 companies from Spain and Belgium are working to outline a condition monitoring strategy which may reduce the impact of some hydraulic pitch system failure modes on the wind turbine's design load cases.

In that sense, the consortium will be devoted to identifying otherwise critical failure

modes on the hydraulic pitch subsystem which may be made non-critical, or whose criticality may be reduced, via condition monitoring, and to develop a digital platform to capture and manage the operating data to detect and predict the identified failure modes in time.

The project tasks are divided into three main blocks shown in Figure 4 and summarized below:

- The first block consists of the identification of specific condition monitoring opportunities within a typical hydraulic pitch system, via a failure mode

effect and criticality analysis (FMECA).

A failure mode, effect and criticality analysis of a generic wind turbine hydraulic pitch system has been already carried out according to IEC 60812, in order to identify critical failure modes and to propose monitoring-based mitigation strategies for them.

- The second block consists of the development of the CM strategy to face the prioritized failure modes. In this regard, key parameters to detect the identified failure modes and treatment of raw data in a real operation scenario have been defined. A hybrid model will be developed as a result of the combination of test and real operation data for failure diagnosis.

DOCC-OFF proposes the use of pitch system variables set and measured by the turbine control system, such as the cylinder positions, the accumulator pressures and the hydraulic valve inputs to automatically diagnose hydraulic pitch system failures. This can then be used to both send protective commands to the turbine control systems, e.g. to limit power output, and plan maintenance sorties more efficiently. The process is shown in Figure 5.

First of all, the signals to monitorize the identified failure modes are extracted from the FMECA. All the required configuration and parameters regarding data collection and storage have been considered to provide the platform with the information to perform the configuration management of the hydraulic pitch system. These include

Digitalization Of Critical Components in OFFshore wind turbines [DOCC-OFF]

Objective: to identify the failure modes of a pitch/hydraulic system and to develop data-based analytical solutions



Figure 4 Infographic of the DOCC-OFF project

‘In a later stage, the developed digital platform will be validated in a testing site, and the opportunities to demonstrate the full integrated solution will be analysed.’

measurement frequencies and aggregation time period. Consequently, the treatment of raw data measured by sensors is described in order to perform relevant aggregations and to obtain the appropriate format of data to be stored and used. Feasibility for condition monitoring in a real time operating scenario is seized through the specification, including availability of data with commercial sensors and technical limitations regarding data retrieval and manipulation. On the whole, the data defined in this stage must ensure the feasibility of the hybrid model that will be developed in the next steps of the DOCC-OFF project.

- The third block consists of the specification of a scalable and modular digital architecture to contain all the developments chased during the project and development of a digital platform that will capture and manage data from the monitored components.

To develop this digital platform, a unique and new design system will be developed to guarantee the flexibility and customization process that will be needed. This will allow to reduce the probability of not detecting the identified hydraulic pitch system failure modes in time, and therefore also the impact of them of on the wind turbine's design load cases.

Findable, accessible, interoperable and reusable data are qualities involved in the DOCCOFF data governance model. In addition, the digital architecture specified ensures essential attributes like scalability, maintainability, sturdiness and cybersecurity, among others. Each module covers a different duty in the data management process, from guaranteeing a communication flow and interactivity between the different data sources to the user interaction layer.

In a later stage, the developed digital platform will be validated in a testing site, and the opportunities to demonstrate the full integrated solution will be analysed. This will be done in 4 different stages as

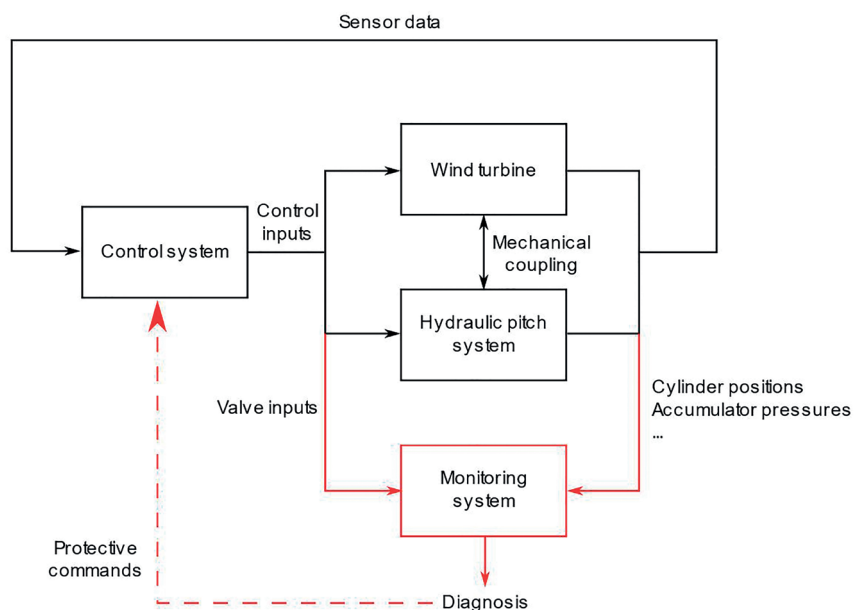

Figure 5 Hydraulic pitch system monitoring

described below:

Validation specifications

Requirements of the testing sites and different test-benches will be evaluated and defined, as well as validation technologies, tests to be carried out, results and performance indicators.

Validation at system level

The solution will be validated on an existing singular testing infrastructure.

System integration

Different building blocks developed in the previous stage (models, sensors, efficient communications, HPC architectures, secure data transfer protocols, data analytics, etc.) will be integrated.

Analysis at wind turbine level

A technical and economic study of the possible installation of instrumented component on wind turbine for validation during in field operations will be carried out.

The experiences and developments acquired in the monitoring of the failure modes in a specific subsystem can be applied to other critical subsystems of wind turbines, positioning DOCC-OFF as a best-practice that can be replicated and scaled up to other systems within the wind turbine.

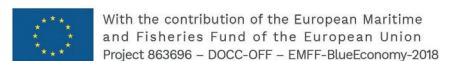

The content of this article represents the views of the author only and is his/her sole responsibility; it cannot be considered to reflect the views of the European Commission and/or the Executive Agency for Small and Medium-sized Enterprises (EASME) or any other body of the European Union. The European Commission and the Agency do not accept any responsibility for use that may be made of the information it contains