



STR-21G Sun Tracker with MS-57 Pyrheliometer next to the MS-90 DNI Sensor at EKO Instruments Ami Solar Park, Japan

# Developing a new angle on solar irradiance

**Words:** Mário Pó, PhD, lead scientist and Dmytro Podolskyy, Business Development Manager, both at EKO Instruments EU

Our reliance on fossil fuels is ending. Not because we've run out of oil, gas, or even coal. Not even because the harmful environmental impact of these resources is finally, sadly, irrefutable; except to the most dogmatic of climate change deniers. No. Our reliance on fossil fuels is ending because of the advances we have made in renewables, wind, hydro, geothermal, and solar; especially solar.



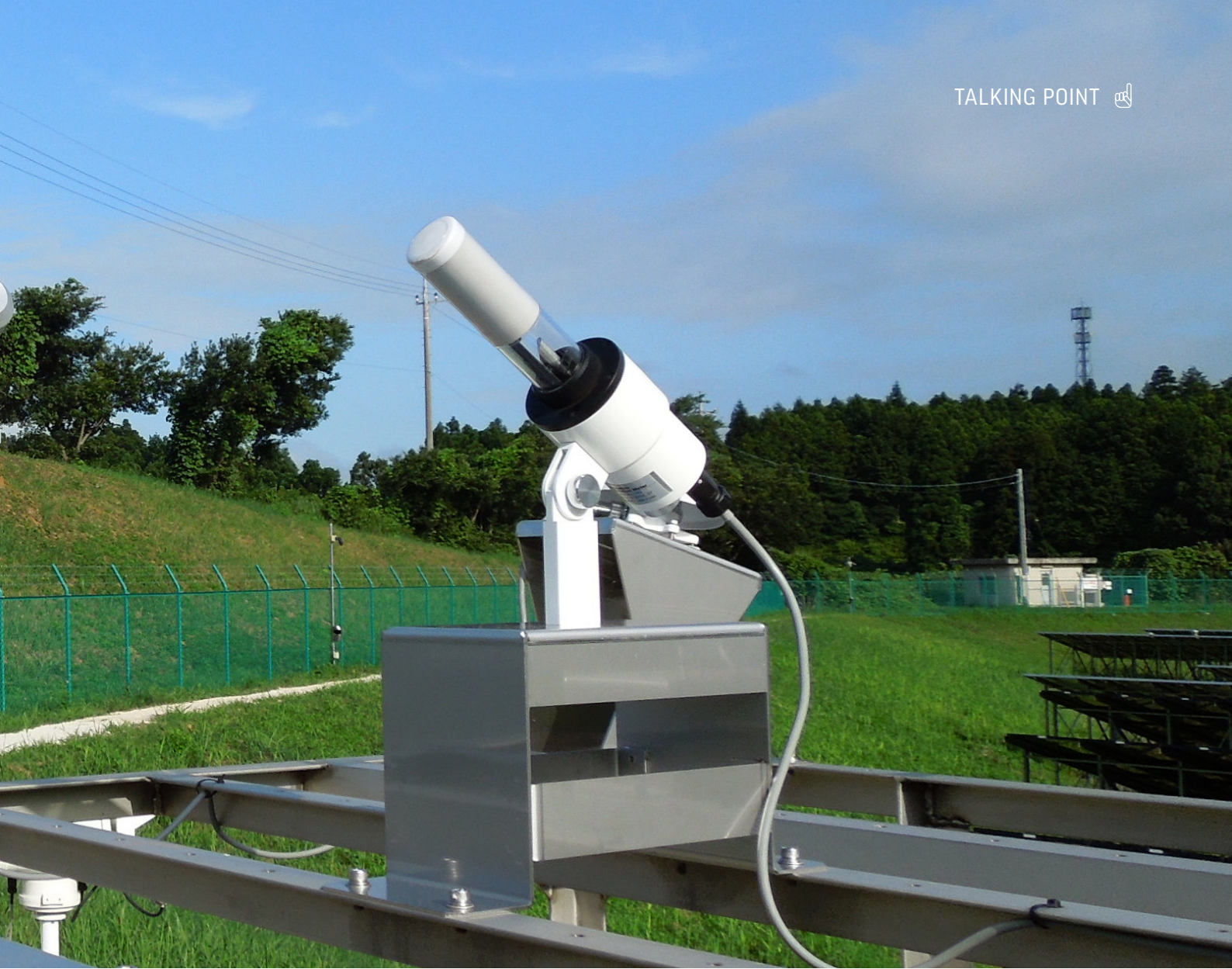

Dmytro Podolsky

Solar energy has always been integral to life on earth, and now through advancements in technology, increased efficiency, and the hard truth of economics, solar is fast becoming the definitive energy source of the next era in human civilization.

Solar technologies have broad applications,



Mário Pó, PhD

from off-grid stand-alone photovoltaic (PV) systems to Giga-Watt (GW) scale PV power farms, or Concentrated Solar Power (CSP) plants, and more. Their productivity is defined by their ability to transform solar radiation into electrical and thermal power efficiently. Increased efficiency in any

application is equal to more energy produced; to more money saved, or earned.

#### **Know your input, understand your output**

To define the efficiency of any solar technology, we need accurate data on the input and output energy. That is, how much potential energy is available from the sun versus how much the system has produced. Knowing and fully understanding these two quantities is crucial in any solar energy installation, not just for process optimisation, but also in order to detect problems.

Solar radiation, sunlight, is, however, a highly variable resource. Season, time of day, location, even the diffusion of light in the sky all impact on input and potential output.

Diffuse and ground reflected solar radiation is increasingly being used to improve energy yields in more traditional installations. Bi-facial solar PV modules allow solar plant owners to harvest radiation from the sky, and also, from ground reflected light, increasing their total yields. Special ground engineering can also enhance the ground albedo, further increasing the amount of incoming energy to a bifacial solar panel.

Different solar cell technologies are also more sensitive to various components of the solar spectrum. 'Perovskite' solar cells, for instance, absorb the shorter wavelengths of the solar spectrum more efficiently. Whereas 'Solar Tandem' cells combine more than one spectrally selective material, potentially overtaking traditional Silicon solar modules for efficiency.

Monitoring irradiance in all its components is essential to the effective planning, and management of a solar power plant.

Individual instruments can be deployed as part of a solar monitoring station to measure each component. For example, a solar monitoring station with an automated tracker, a pyrheliometer that is always pointing at the sun and two pyranometers, one shaded by a special shading ball or disc and one unshaded, can together measure Direct Normal Irradiance (DNI) and Diffuse Horizontal Irradiance (DHI) simultaneously.

The second pyranometer measures Global Horizontal Irradiance (GHI) independently providing redundancy in the measurement data in case one of the sensors becomes soiled, or out of level; the error in the data can be easily detected by evaluating the radiation closure.

Such a system is the most precise way to measure solar irradiance provided that all

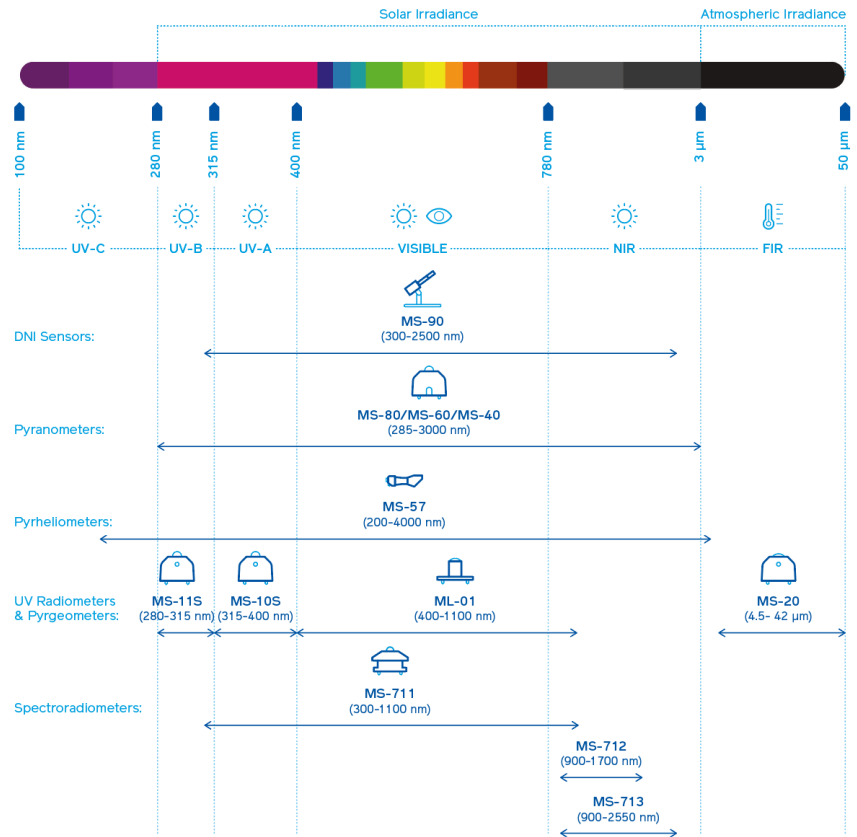

EKO sensors, mapped to solar irradiance

WORKING PRINCIPLES: TITLING, ROTATION, DETECTION.

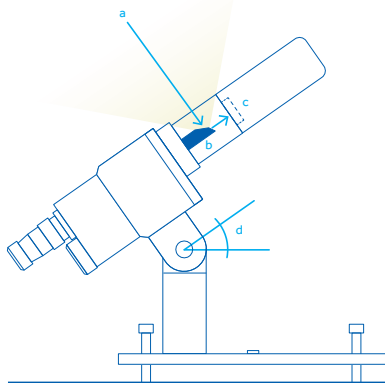

- Left. Sensor schematic:
- a. Direct solar beam
  - b. Rotating mirror: reflects the beam to the detector
  - c. Pyroelectric detector: measures pulse
  - d. Tilted angle: optimized to latitude

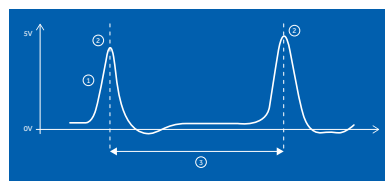

- Above. MS-90 Beam:
1. Analog output
  2. Peak values proportional to Direct Normal Irradiance
  3. Time approx. 15 sec.

POSITIONING: ORIENTATION

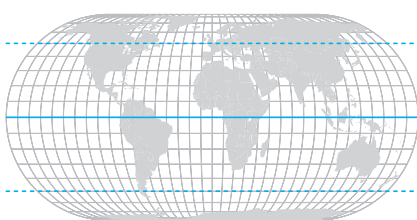

- Northern hemisphere  
MS90 oriented to the equator
- Equator
- Southern hemisphere  
MS90 oriented to the equator

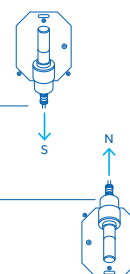

How it works: the MS-90 DNI Sensor

sensors are properly calibrated, and the tracker has the highest pointing precision and reliability. However, this sort of system isn't always the most practical solution. Whether due to budget constraints, or simply a lack of space, a more compact option is sometimes a necessity.

'Tracker-less' Alternatives

There are several solutions available on the market that can measure at least two components of solar radiation, and calculate the third.

For example, two pyranometers, a shaded and unshaded one, could be used to measure GHI and DHI, enabling the calculation of the DNI. The shading can be provided by a shadow ring or an automated rotating shadow band. However, these methods often require high maintenance and have relatively high measurement uncertainties due to the fact that the shading elements cover a much larger part of the sky than the shading ball on a full-sized solar monitoring station; this can lead to errors in the measurements of diffuse and global irradiance.

Another challenge to the accurate calculation of DNI is the often-high variability in atmospheric conditions at most sites. The composition of air is changeable, its humidity, the presence of aerosols and airborne particles such as dust, sand, soot,





MS-90 Plus+

fog, ice crystals, smog, and even sand can all affect the dispersal of solar light.

So, while 'tracker-less' solutions can be a practical alternative, they have traditionally been regarded as 'second-best'. In an industry where the accuracy of the monitoring solution, and in turn the efficiency, and economic viability of an application are paramount, second-best simply isn't good enough.

#### A Unique Solution

That's why EKO Instruments developed the MS-90 DNI Sensor a new approach featuring a unique internal rotating mirror design that can measure DNI without requiring a separate tracker. The distinct shape of the mirror reflects the direct solar beam to a very fast pyroelectric detector, allowing the MS-90 to measure direct radiation without the whole unit tracking the sun as a much larger solar monitoring station would.

We measured the MS-90 against reference pyrheliometers at the National Renewable Energy Laboratory (NREL) in Colorado, USA; successfully demonstrating the accuracy and viability of this unique solution.

The MS-90 accurately measures DNI without a sun tracker. The spectral sensitivity of the sensor covers a wide spectrum from 300 to 2500nm; enabling accurate measurements of DNI for both PV and CSP applications, as well as in meteorological observations. And as it's calibrated outdoors using a pyrheliometer, not in the lab, the MS-90 DNI Sensor is traceable to the World Radiation Reference (WRR).

#### Meet the MS-90 Plus+

We've combined the unique internal rotating mirror design of the MS-90, with our industry-leading, fast response, Class A MS-80 Pyranometer and original C-Box smart interface, to create the MS-90 Plus+. A new, total solar irradiance solution.

Additional features include an integrated GPS receiver, enabling the C-Box to calculate the diffuse component of the irradiance based on the DNI data from the MS-90 and the GHI data from MS-80; plus, a MODBUS 485 RTU output for easy connection to any digital data acquisition system.

The MS-80 Class A Pyranometer with a wide spectral range also provides the most

accurate measurement of GHI due to its low thermal offset and fast response time; making it possible to measure fast changes in irradiance.

And with no external moving parts the MS-90 Plus+ is easily installed and maintained.

Find out more about the MS-90 Plus+ and other solar monitoring solutions.

Contact [info@eko-eu.com](mailto:info@eko-eu.com)

[www.eko-eu.com](http://www.eko-eu.com)

**Mário Pó, PhD** is lead scientist at EKO Instruments EU, and received his doctoral degree at the University of Lisbon. His areas of expertise include photovoltaic systems, solar irradiance measurements and instrumentation.

**Dmytro Podolsky** is Business Development Manager at EKO Instruments EU. He graduated from TU Delft with a degree in Applied Physics and Nanotechnology and has since gone on to support industrial solar initiatives and scientific research projects around the world.